

DR. MERCOLA®



True HEPA Air Purifier with ODOGard®

Reduces Odors with ODOGard® Technology

Filters 99.97% of particles as small as 0.3 microns

Purifies 450 ft² of air 2x per hour

DR. MERCOLA®

True HEPA Air Purifier with ODOGard®

The True HEPA Air Purifier with ODOGard® is a powerful system that transforms stale, indoor air into fresh, clean air for you and your family with ease. Its innovative technology purifies 450 square feet of air twice per hour, as the air naturally circulates through the front of the unit and out the top. This unit is ideal for spaces larger than your standard room but smaller than a three-bedroom home, such as common areas and studio apartments.

Filters 99.97% of particles as small as 0.3 microns in the air, including:



Pollen



Dust



Smoke



Pet Dander



Odor



VOCs

DR. MERCOLA®



True HEPA Air Purifier with ODOGard®

Reduces Odors with ODOGard® Technology

Filters 99.97% of particles as small as 0.3 microns

Purifies 450 ft² of air 2x per hour

DR. MERCOLA®

Multilayered System with 4-Stage Purification Process

True HEPA Filter + ODOGard®

Reduces airborne particles like pollen and other allergens such as dust and pet dander while reducing unwanted odors

Washable Pre-Filter

Captures large particles like dust, cotton, wool and pet hair

Germicidal UV-C Light

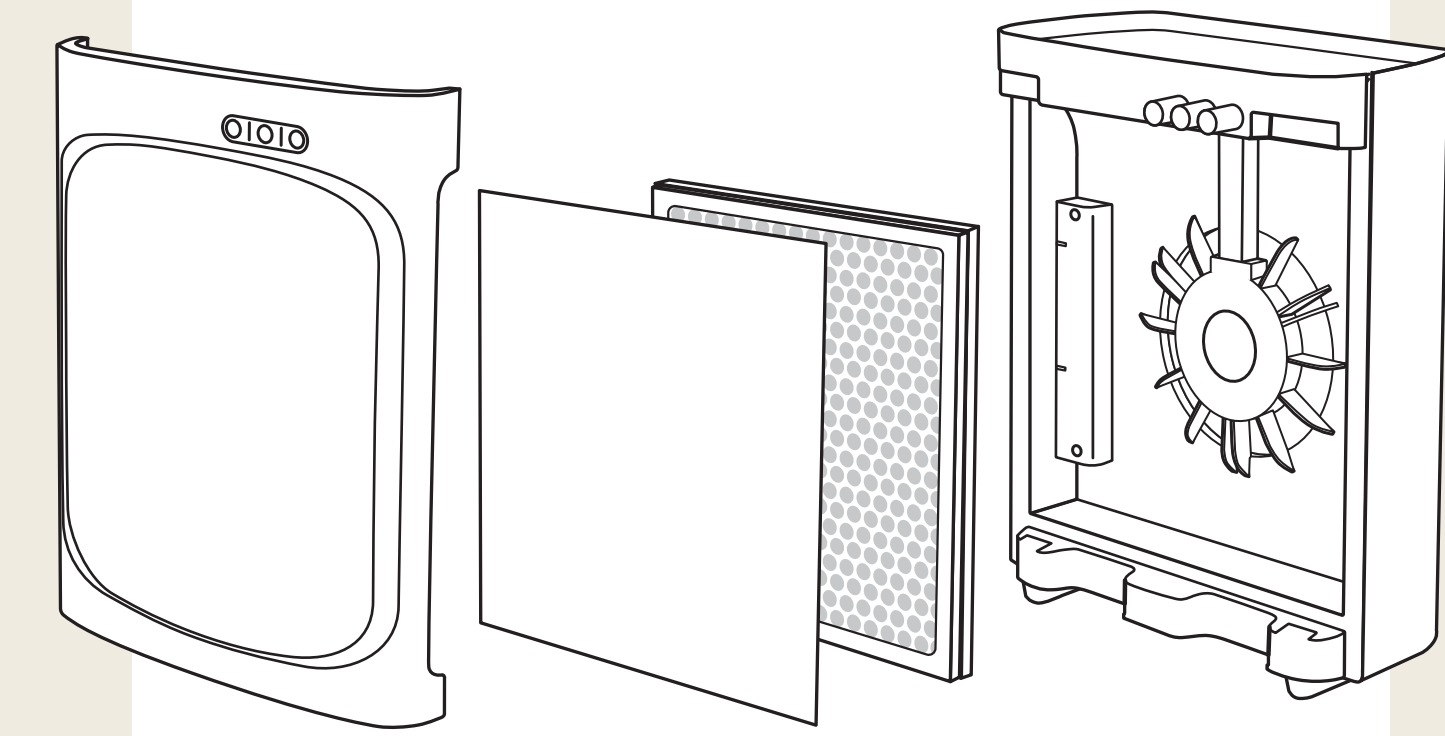

Product Specifications

Input Voltage: 120VAC | 60Hz
Power Consumption: 55 watts (on highest setting)
Unit Dimensions: 16" H x 12.75" W x 7.25" D
Unit Weight: 9 lbs
Effective Area: up to 450 sq. ft. twice per hour
Photocatalytic Filter: 254 nm germicidal UV Light
Noise Level: less than 30 dB (low fan setting)
less than 55 dB (high fan setting)
Fan Speeds: 3 settings
Timer: 2hr, 4hr, and 8hr
Warranty: One-Year Limited Warranty

Meets California ozone emissions limit: CARB certified

CONFORMS TO UL 610, 507



Intertek 3136487

DISTRIBUTED BY: NHP, 125 SW 2nd Place
Cape Coral, FL 33991 USA (877) 985-2696
Made in China
EPA EST # 91680-CHN-1

