

DR. MERCOLA®



WHOLE HOUSE FILTER CARTRIDGE REPLACEMENT

Changing the Filter Cartridges

1. Shut the filter system off at the shut off valve. Relieve the pressure in the water line by running water for 2-3 minutes at the nearest faucet.
2. Place a bucket under the filter housing to catch water. Press the pressure release button. Skip if your model does not have one. Using the wrench supplied with your filter system, open the filter housing by turning the lower ring clockwise. Remove the expired filter cartridge.
3. If necessary, clean the inside of the filter housing with mild soapy water, rinse thoroughly and dry.
4. Place a new filter cartridge in the center of the filter housing.
5. Clean the housing o-ring and lubricate it with silicone grease. Seat the o-ring into the proper groove and reattach the housing by screwing it back onto the top half of the unit using the wrench. Do not over-tighten. **NOTE: DO NOT USE PETROLEUM JELLY as lubrication on the system or o-rings.**
6. After reassembly, turn the system back on at the shut off valve.
7. Run water, with the bucket still under the filter housing. Check for leaks.

Replace the filter cartridges if there is a noticeable reduction of water in the system, or if the filter cartridge becomes heavily discolored.

Replace 5 Micron every 1-3 months and .35 Micron every 6-12 months (depending on sediment levels)

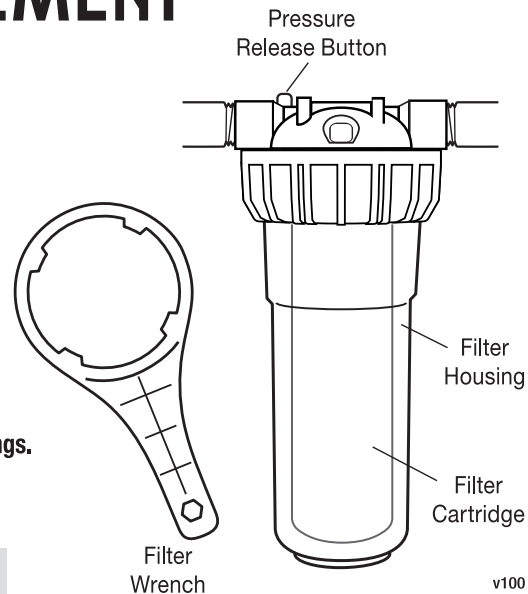

FOR HOUSEHOLD USE ONLY
DISTRIBUTED BY: NHP, 125 SW 3rd Place
Cape Coral, FL 33991 USA (877) 985-2696

To order additional Filter Cartridges, visit waterfilters.mercola.com or contact Mercola Customer Service at (877) 985-2696.